

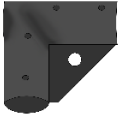











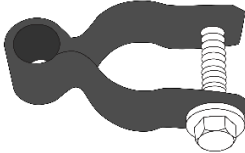

Deer Fence Sleeved Access Gate Installation Instructions

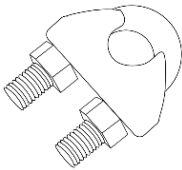
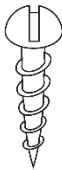
Note: If a tension system was purchased, please refer to tensioning kit instructions **BEFORE** these instructions.

HARDWARE PARTS			
<p>A</p> <p>QTY: 2</p>  <p>Corner Elbow Heavy Duty 1 5/8" Black</p> <p>SKU: DE8116</p>	<p>B</p> <p>QTY: 1</p>  <p>1 5/8" Drive Cap</p> <p>SKU: DE2812</p>	<p>C</p> <p>QTY: 4</p>  <p>Corner Elbow Hex 1 3/8" Heavy Duty Black</p> <p>SKU: DE8112</p>	<p>D</p> <p>QTY: 2</p>  <p>End Clamp Black Galvanized Steel 1 3/8" x 1 3/8"</p> <p>SKU: DE8154</p>
<p>E</p> <p>QTY: 2</p>  <p>Turnbuckle Gate Tension Assembly</p> <p>SKU: DE8464</p>	<p>F</p> <p>QTY: 2</p>  <p>Male Hinge Black Galvanized Steel 1 5/8"</p> <p>SKU: DE8212</p>	<p>G</p> <p>QTY: 2</p>  <p>Female Hinge Black Galvanized Steel 1 3/8"</p> <p>SKU: DE2830</p>	<p>H</p> <p>QTY: 2</p>  <p>Fork Latch Assembly 1 5/8" Black</p> <p>SKU: DE8180</p>
<p>I</p> <p>QTY: 2</p>  <p>Monofilament Connector Clip</p> <p>SKU: DE2830</p>	<p>J</p> <p>QTY: 24</p>  <p>Self-Tapping Screw 3/4"</p> <p>SKU: DE9978-1</p>	<p>K</p> <p>QTY: 2</p>  <p>Carriage Bolt w/Washer & Nut Hot Dip Galvanized - 5/16" x 2"</p> <p>SKU: DE8044</p>	<p>L</p> <p>QTY: 4</p>  <p>Carriage Bolt w/Washer & Nut Hot Dip Galvanized - 3/8" x 2"</p> <p>SKU: DE8054</p>
<p>M</p> <p>QTY: 8</p>  <p>Carriage Bolt w/Washer & Nut Hot Dip Galvanized - 5/16" x 2 1/2"</p> <p>SKU: DE8066</p>	<p>N</p> <p>QTY: 1 pk</p>  <p>8" High Strength Nylon Self-Locking Ties – 50pk</p> <p>SKU: DE2853</p>	<p>O</p> <p>QTY: 2</p>  <p>Black Ground Sleeve for 1 5/8" Post</p> <p>SKU: DE8196</p>	<p>Recommended Tools (not included)</p> <ul style="list-style-type: none"> Power Drill with 5/16" Drill Bit Socket Wrench 5/16" or Adjustable wrenches Tape Measure Level Sledgehammer Earth Auger/Digging Bar

Pipe Part List for 8' Deer Access Gate(Sleeved)

	8'H x 3' W			8'H x 4' W			8'H x 5' W			8'H x 6' W			8'H x 7' W		
	Qty	Pipe Part	SKU	Qty	Pipe Part	SKU	Qty	Pipe Part	SKU	Qty	Pipe Part	SKU	Qty	Pipe Part	SKU
Vertical Pipe for Gate Door (B)	2	1 3/8" x 87"	DE8353-087	2	1 3/8" x 87"	DE8353-087	2	1 3/8" x 87"	DE8353-087	2	1 3/8" x 87"	DE8353-087	2	1 3/8" x 87"	DE8353-087
Horizontal Pipe for Gate Door (C)	2	1 3/8" x 33"	DE8353-033	2	1 3/8" x 45"	DE9553-045	2	1 3/8" x 57"	DE8353-057	2	1 3/8" x 69"	DE9553-069	2	1 3/8" x 81"	DE9553-081
Center Bar (D)	1	1 3/8" x 32"	DE8353-032	1	1 3/8" x 44"	DE8353-044	1	1 3/8" x 56"	DE8353-056	1	1 3/8" x 68"	DE9553-068	1	1 3/8" x 80"	DE8353-080
Spreader Bar (O)	1	1 5/8" x 43.5"	DE8358-0435	1	1 5/8" x 55.5"	DE8358-0555	1	1 5/8" x 67.5"	DE8358-0675	1	1 5/8" x 79.5"	DE8358-0795	1	1 5/8" x 91.5"	DE8358-0915
Frame Posts (N)	2	1 5/8" x 108"	DE8358-108	2	1 5/8" x 108"	DE8358-108	2	1 5/8" x 108"	DE8358-108	2	1 5/8" x 108"	DE8358-108	2	1 5/8" x 108"	DE8358-108

Deer Fence Sleeved Access Gate Installation Instructions

1. Insert the **CORNER ELBOWS (A)** onto the ends of the **SPREADER BAR (O)**. Make sure the open ends of the elbow are **FLUSH** with the ends of the spreader bar. Using the holes on the **CORNER ELBOWS (A)** as a guide, use a 5/16" drill bit (**NOT INCLUDED**) to drill holes into the **SPREADER BAR (O)**. Flip the **SPREADER BAR (O)** over and repeat drilling on opposite side. Secure the **CORNER ELBOWS (A)** to the **SPREADER BAR (O)** using **CARRIAGE BOLTS (M)**. Do not fully tighten bolts.

Note: It is **EXTREMELY** important to ensure the **CORNER ELBOWS (A)** are **FLUSH** with the **SPREADER BAR (O)** as this determines where your gate frame posts are located. If the open ends face upwards or are not flush, your gate frame will not fit your gate door. Double check instructions before drilling holes.

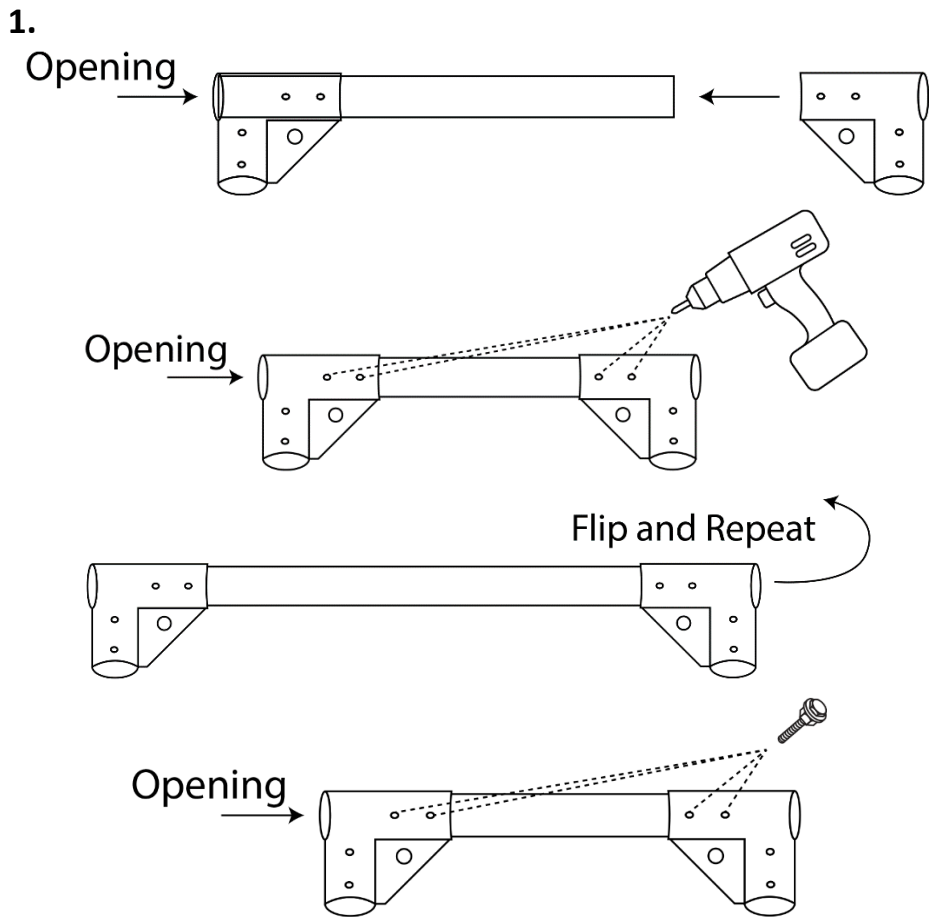

2. Set the **SPREADER BAR (O)** where the gate is located along the fence line. Where the **CORNER ELBOWS (A)** come to is the location where you will drive in the **GROUND SLEEVE (P)** for your **FRAME POSTS (N)**. Mark this location. Using the **DRIVE CAP (B)** and a sledgehammer, drive the **GROUND SLEEVES (P)** into the ground where previously measured, as close to the ground as possible. Care should be taken to ensure that the sleeves are as straight as possible.

Note: On hard ground it may be necessary to use an **EARTH AUGER (Sold Separately; SKU: DE8189)** or **DIGGING BAR** to make a hole before driving the ground sleeves in.

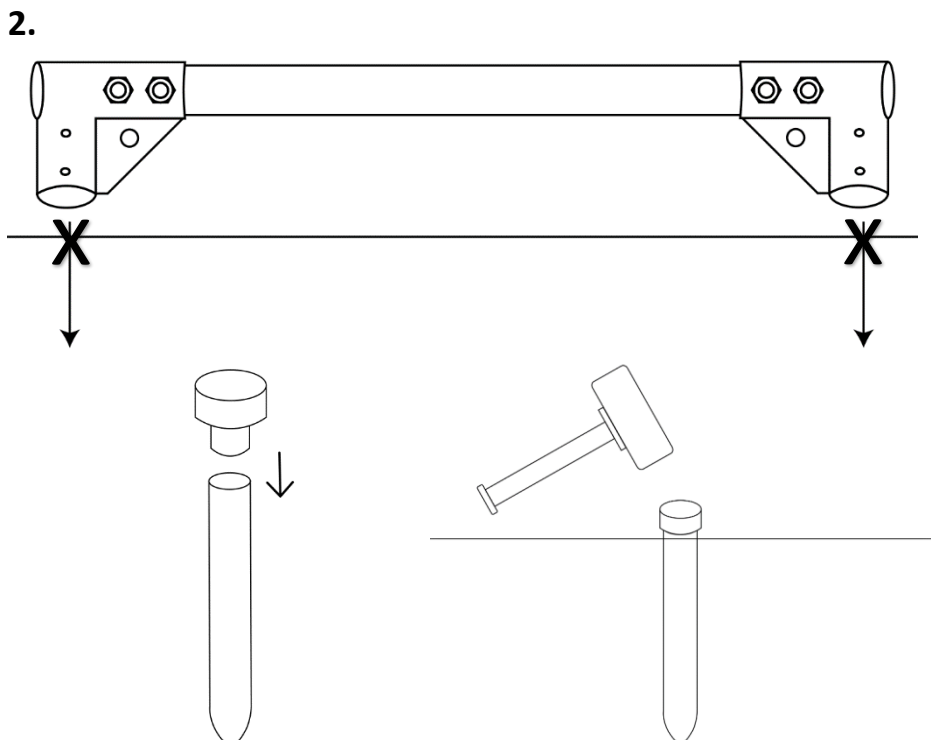

3. Insert the **FRAME POSTS (N)** into the **CORNER ELBOWS (A)** of the **SPREADER BAR (O)**. Use a 5/16" drill bit to drill holes into the **FRAME POSTS (N)** using the holes of the **CORNER ELBOWS (A)** as guides. Flip the frame over and repeat drilling on opposite side. Secure the **FRAME POSTS (N)** to the **CORNER ELBOWS (A)** using **CARRIAGE BOLTS (M)**. Tighten all bolts before sliding the assembled **GATE FRAME** into the **GROUND SLEEVES (P)**.

Note: Take time to measure the distance between your **FRAME POSTS (N)** to ensure they are the same distance apart at the bottom as they are at the top.

3.

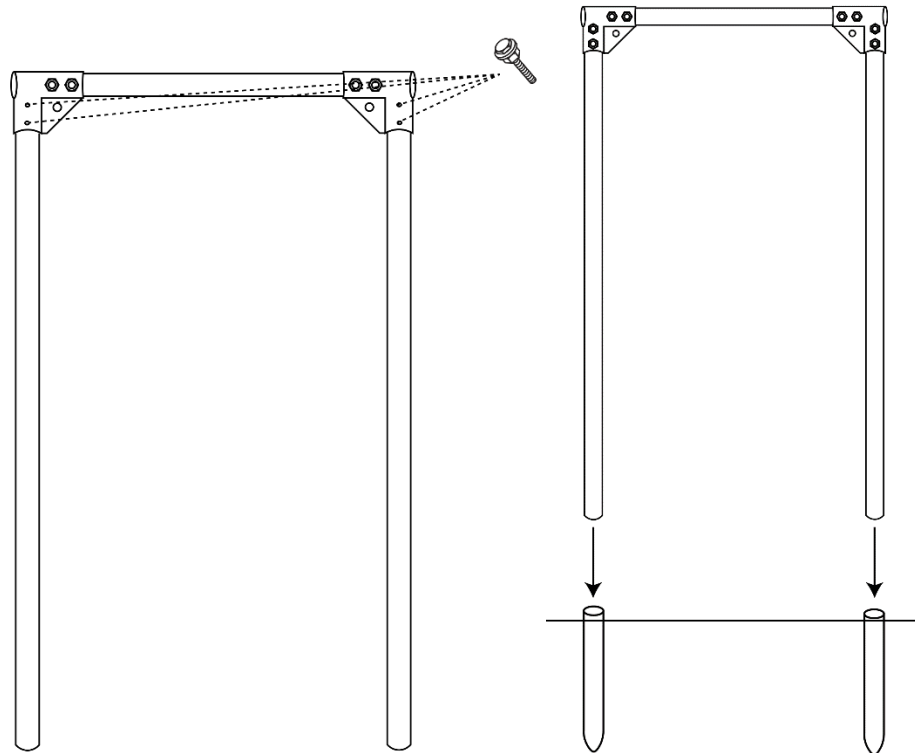
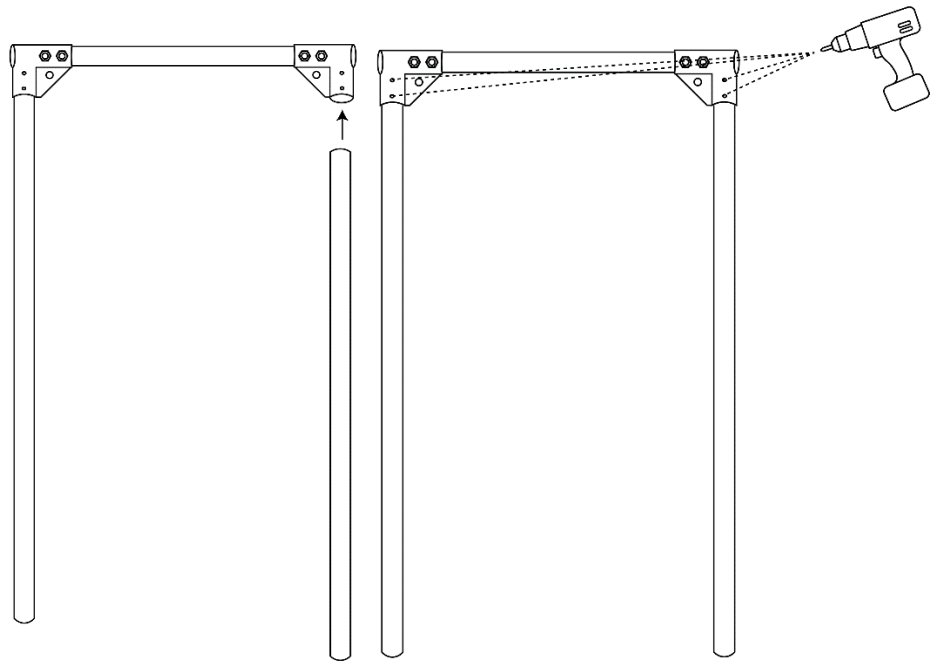

4. Insert **VERTICAL GATE DOOR POST (B)** into **CORNER ELBOW (C)**. Then slide in the **HORIZONTAL GATE DOOR POST (C)** into the **CORNER ELBOW (C)**. The posts do not to be forced into the corner, they should stop along the diagonal weld. Secure the **POSTS** inside the **CORNER ELBOWS (C)** using **SELF-TAPPING SCREWS (J)**. Finally, attach the **CENTER BAR (D)** on both sides of the **VERTICAL GATE POSTS (B)** with an **END CLAMP (D)** on either end. Secure the **END CLAMP (D)** in place with a **CARRIAGE BOLT (K)** on the **CENTER** of each **VERTICAL GATE POST (B)**.

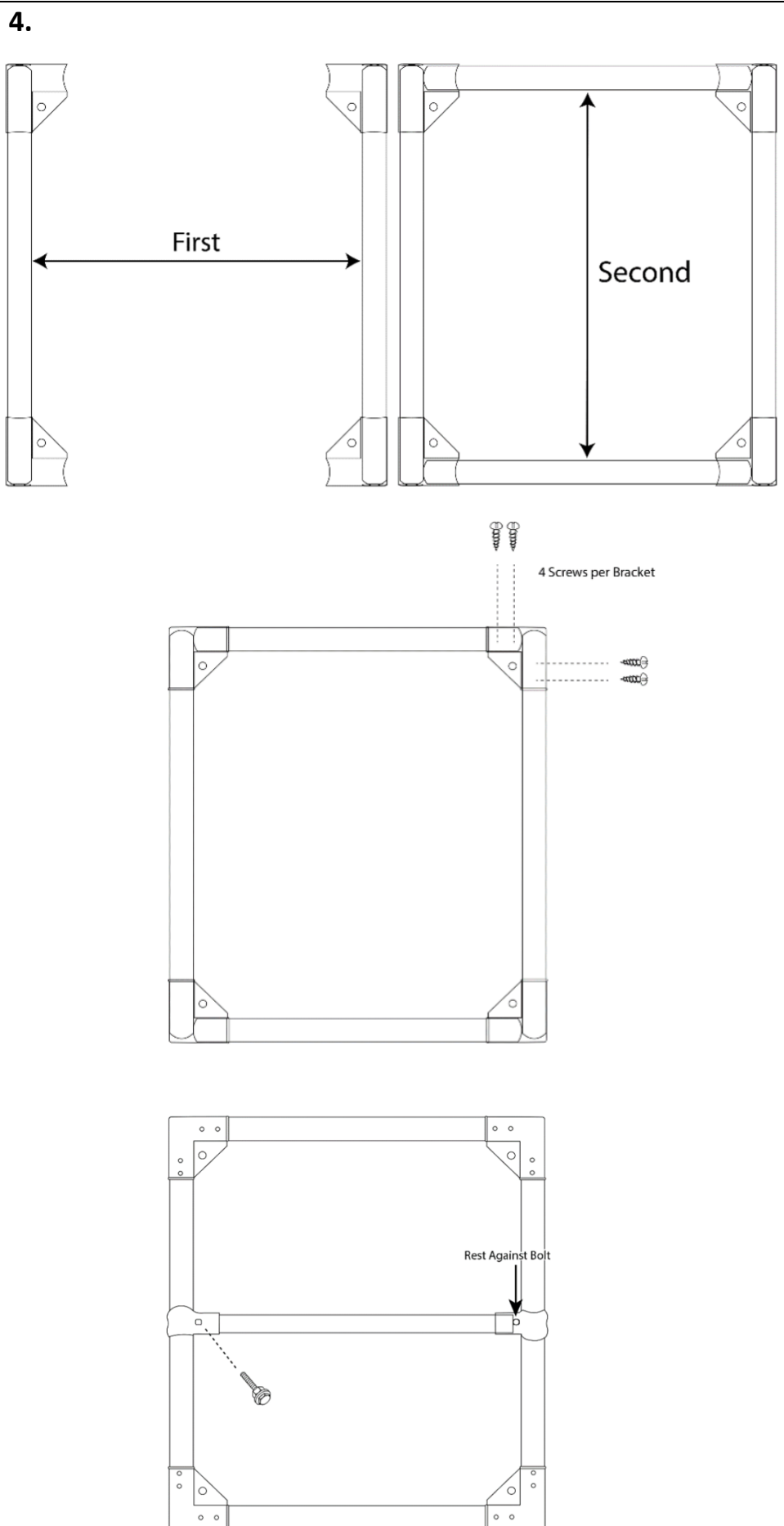

5. Open the **TURNBUCKLE (E)** by twisting both ends. Place the hook end of one **TURNBUCKLE (E)** through the hole in one top **CORNER ELBOW (C)** and stretch the cable diagonally to the hole in the bottom **CORNER ELBOW (C)**. Pass the cable through the **CONNECTION CLIP (I)** and then through the hole in the **CORNER ELBOW (C)**. Pass the end of the cable through the **CONNECTION CLIP (I)** again. Position the **CONNECTION CLIP (I)** close to the **CORNER ELBOW (C)** and tighten using the small nuts. Repeat on the opposite side creating an "X" across the gate. Evenly tighten the **TURNBUCKLES (E)** on each side to keep the gate square.

5.

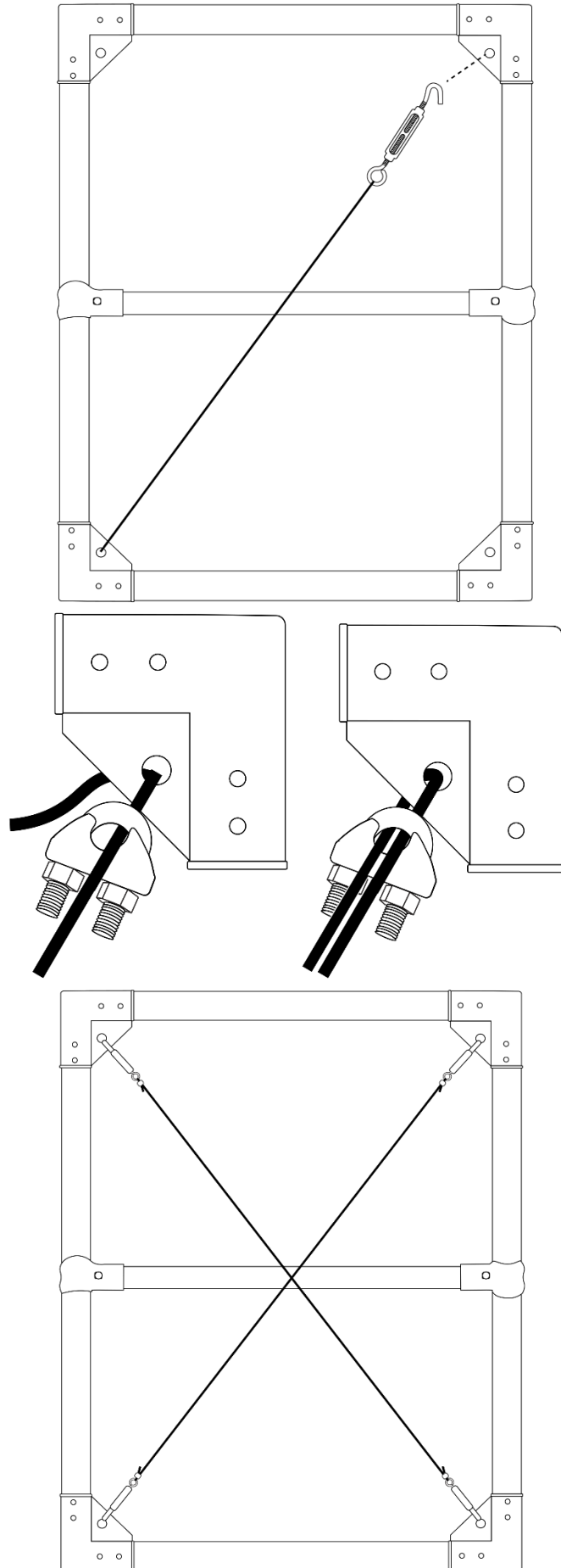

6. On one side of the newly assembled gate door, measure **18"** from the **TOP** and **18"** from the **BOTTOM** of the door. Attached the **FEMALE HINGE (G)** at these marked points with a **CARRIAGE BOLT (L)**. On the opposite side of the gate door, attach the **FORK LATCH (H)** at the same height as the **FEMALE HINGES (G)**; **18"** from the **TOP** and **18"** from the **BOTTOM**.

Note: You can attach the hinges and latches to either side of the door frame to accommodate which way it will open in the system.

6.

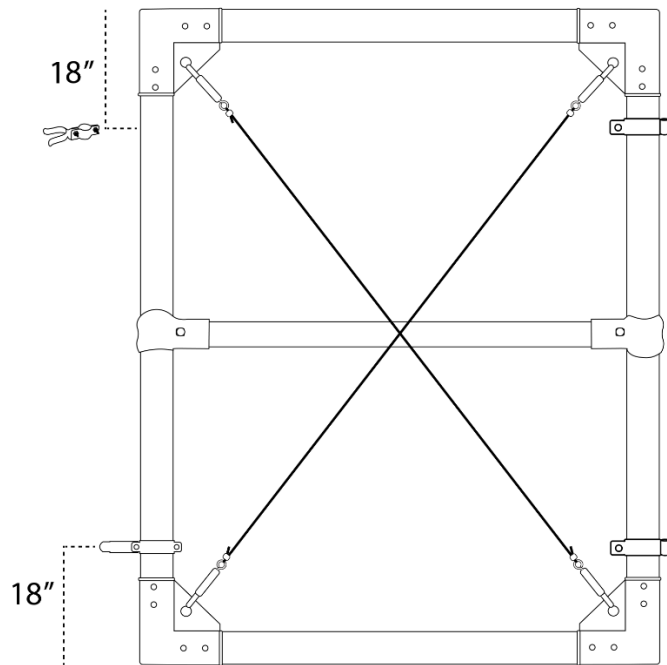
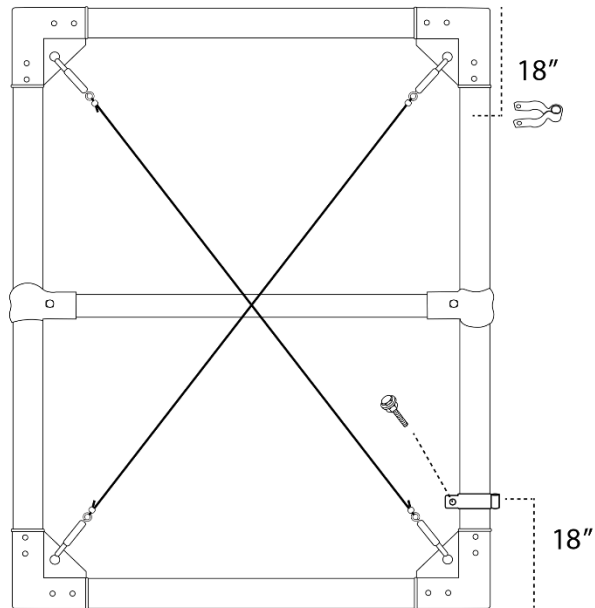

7. Attach the **MALE HINGES (F)** to one side of the **FRAME POST (N)** and secure them with a **CARRIAGE BOLT (L)**. Do not tighten the bolts completely. Position the **GATE DOOR** on the **INSIDE** of the **FRAME POSTS (N)** at the desired height, then slide the **MALE HINGES (F)** up into the **FEMALE HINGES (G)** to attach the gate. Once positioned, you can tighten the **CARRIAGE BOLTS (L)** of the **MALE HINGES (F)**. Finally, cover the entire **GATE DOOR** with your fence mesh (**NOT INCLUDED**) and fasten the mesh to the **GATE DOOR** using **SELF-LOCKING TIES (O)**. Trim excess material as needed.

Note: You do not need a tie for every square on the mesh. We recommend 1 tie for every 1' along the pipe of the gate door.

7.

